

# MemxPro Half Slim SATA EB31 Series

SLC like, 20K+ P/E cycles

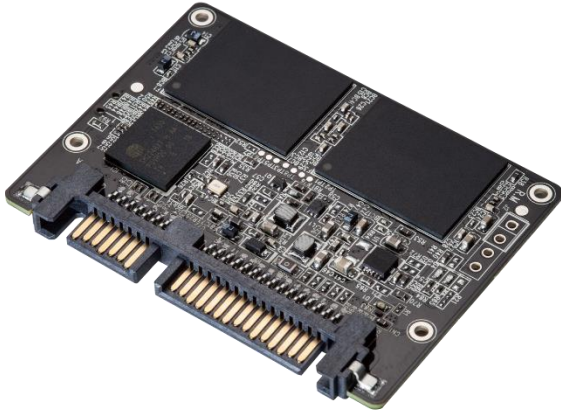

## Features

- SATA III, compliant with JEDEC MO-297
- StrongMLC, DRAM-less, up to 128GB capacity
- Commercial/extended/wide temp. solutions
- Built-in ECC and OCP/OVP
- NCQ/TRIM/SMART support
- mSMART storage device monitoring

## Specification

Product Model	Half Slim SATA EB31
Interface	SATA III
Form Factor	Half Slim SATA (M0297)
Flash Type	StrongMLC
Max. Channel	4
Density	8GB~128GB
Sequential R/W (MB/sec, max.)	514/421
Operating Temperature	0°C~+70°C/-25°C~+85°C/-40°C~+85°C
Max. Power Consumption	2.75W (5V 550mA)
Dimension (L x W x H/mm)	39.8x54x4
Operating Voltage	5V±10%
Storage Temperature	-55°C~+95°C
External DRAM Buffer	N/A
Thermal Sensor	✓
DEVSLP Mode	< 5mW
ATA Security	✓
S.M.A.R.T.	✓
TRIM	✓
Vibration	20G (7~2KHz)
Shock Resistance	1500G@0.5ms
MTBF	>3 million hours

# Dimensions

Unit: mm

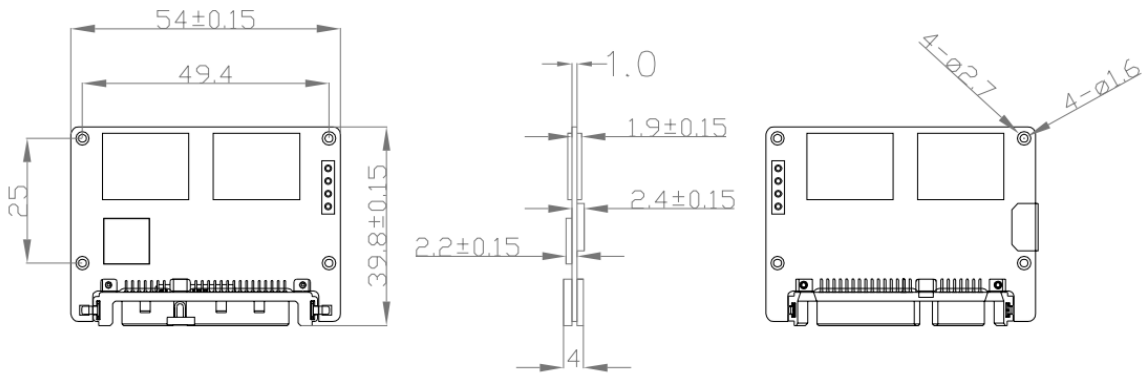

# Ordering Information

Capacity	Commercial (0°C~70°C)	Extended (-25°C~85°C)	Industrial (-40°C~+85°C)
8GB	FEHSS-08GTBS4X2C2	FEHSS-08GTBS4X2E2	FEHSS-08GTBS4X2W2
16GB	FEHSS-16GTBS4X4C2	FEHSS-16GTBS4X4E2	FEHSS-16GTBS4X4W2
32GB	FEHSS-32GTBS4X2C2	FEHSS-32GTBS4X2E2	FEHSS-32GTBS4X2W2
64GB	FEHSS-64GTBS4X4C2	FEHSS-64GTBS4X4E2	FEHSS-64GTBS4X4W2
128GB	FEHSS-A2GTBS4X4C2	FEHSS-A2GTBS4X4E2	FEHSS-A2GTBS4X4W2